

ENVIRO BOX

64 litres

N° 60284

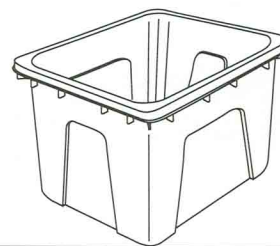

COMPONENTS

Material : high density polyethylene
Standard colour : grey
Other colours on request
(minimal quantity : 2,000)

WALL THICKNESS

0.26 cm (0.102 in.)

STANDARD WEIGHT

(± 2%)
1.93 kg (4.3 lb.)

RATIO

Nesting 10 : 1

PACKING

SHIPPING

Pallet dimensions :
122 cm x 102 cm x 197 cm h.
48 in. x 40 in. x 77 1/2 in. h.
Volume/pallet : 2.5 m³ (88.3 ft.³)
Weight/pallet (pallet not included) :
386 kg (851 lb.)
Quantity/pallet : 200
Quantity/truck : 4,600

Note : All pallets are stretch-wrapped to protect boxes from dust.

RECOMMENDED UTILIZATION

Pallet dimensions :
122 cm x 102 cm x 53 cm h.
48 in. x 40 in. x 20 7/8 in. h.
Quantity/pallet : 4
(1 row of 4)

Note : Never let boxes overlap edge of pallet.

THERMAL RESISTANCE

From -40°C (-40°F)
to 39°C (102°F)

APPROVALS

Materials are food approved and meet FDA (Food & Drug Administration-USA) and HPB (Health Protection Branch-Canada) standards.
Made accordingly to SPC (Statistical Process Control) standards.

CAPACITIES

Volume	Litres	Gallons	
		imp.	US
Full	64.9	14.3	17.2
In use	59.5	13.1	15.7

PRODUCT DENSITY g / cm ³	MAXIMUM WEIGHT HANDLED	
	kg	lb.
0.5	32.47	71.58
0.6	38.96	85.90
0.7	45.46	100.22
0.8	51.95	114.53
0.9	58.45	128.85
1.0	64.94	143.17
1.1	71.43	157.48
1.2	77.93	171.80
1.3	84.42	186.12
1.4	90.92	200.43
1.5	97.41	214.75

DIMENSIONS

SECURE RECOMMENDED WEIGHT / BOX : 20 kg (45 lb.)

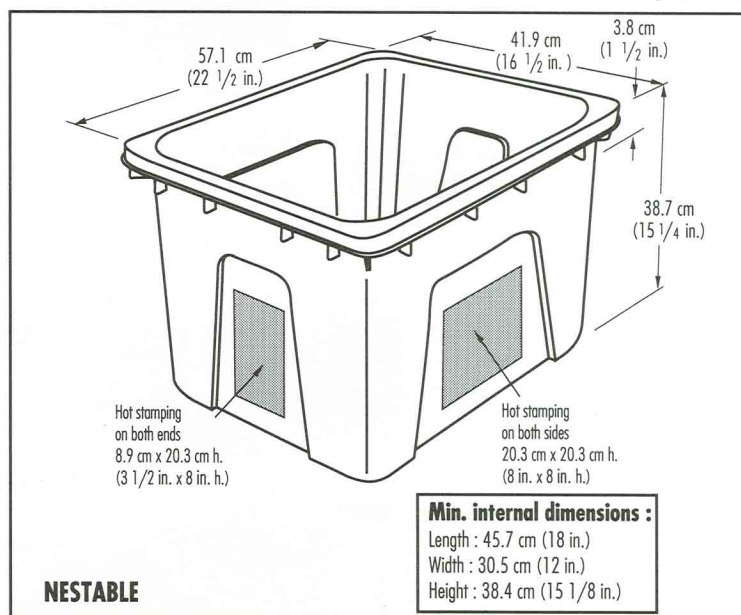

CANADA
IPL INC.
MAIN PLANT
140 Commerciale Street
St. Damien, Quebec
G0R 2Y0
Tel. : (418) 789-2880
Wat (Service) : 1-800- 463-IPL5
Fax : (418) 789-3153

BRANCHES
TORONTO
111 Advance Blvd.
Brampton, Ontario
L6T 4H8
Tel. : (416) 791-5895
Fax : (416) 791-2500

MONCTON
700 Malenfant Street
Dieppe, New Brunswick
E1A 5V8
Tel. : (506) 857-8210
Fax : (506) 859-8790

UNITED STATES
IPL PRODUCTS, LTD.
MAIN OFFICE
WORCESTER
120 Goddard Memorial Drive
Worcester
MA 01603
Tel. : (508) 831-1318
Fax : (508) 831-1124

BRANCH
DETROIT
7922 Siding Court
Grosse Ile
MI 48138
Tel. : (313) 671-0121
Fax : (313) 671-0121